



Exclusive Calibration System



1.

NO COMPROMISE ON ACCURACY

The Labconcept Nano is a new reference in the field of dimensional metrology. It integrates almost 40 years of knowledge and continuous improvement. It is a remarkable instrument for all measuring tasks that requires extremely high accuracy.

The uncompromising design of the Labconcept Nano offers an ideal and performing platform for checking and calibration of all kinds of gauges and measuring instruments. Checking of internal and external dimensions will be done as a fully automatic procedure by the three motorized axis XYZ and the legendary simplicity of use of the Trimos® WinDHI software.

The Labconcept Nano is completely designed and manufactured in Switzerland according to the highest quality standards. Robustness reliability and longevity is our tradition.

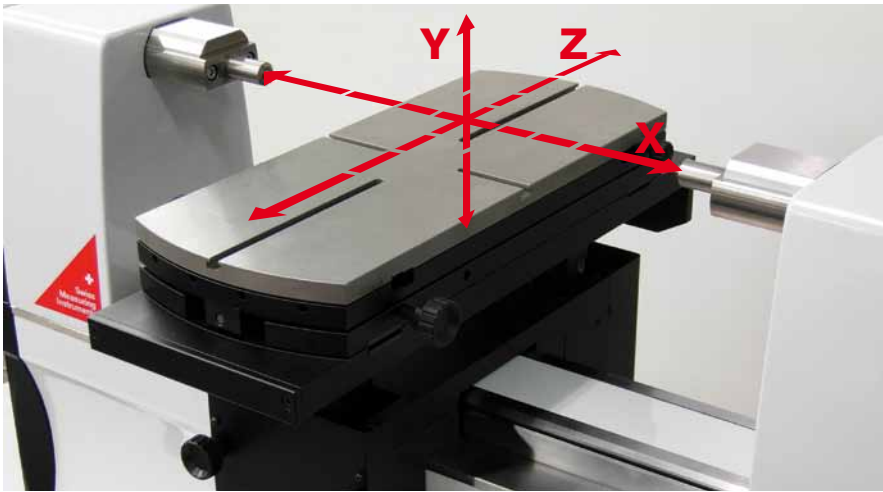

- Unequaled high level of accuracy
- Exceptional repeatability
- Motorized measuring carriage, X axis, selection of speed by software
- Motorized universal measuring table, CNC Y and Z axis with integrated measuring system
- Measuring force (0-12N) and locking of measuring anvil performed by software
- Integrated temperature compensation system
- Absolute measuring range on all models 350 mm
- Application ranges of 350, 600 and 1100 mm
- Measuring of parts up to 60 kg in weight



A New Technological Dimension

The Labconcept Nano combines tradition, experience and a strong technological lead. It integrates the latest measuring and motorisation technologies and can be considered as the first "full digital" calibration instrument.

A regular PC controls all electronic components. This low-power solution avoids heating and keeps the energy, maintenance and repair costs at a reasonable level.

The linear bearings used in all guideways have proven their superiority over all other technologies in terms of precision, wear, rigidity, temperature stability, reliability, dust protection and maintenance. They ensure exceptional repeatability and precision through time.

A. Highly Legible Control unit

Measuring results are clearly displayed on the two screens. The exclusive Win DHI software including control indication of all movements and temperature compensation WinComp offers an understandable overview of the measuring conditions. If needed, the system can be completed with an integrated gauge management software.

B. Fast and Easy Measurements

The motorized measuring table provides quick results for both internal and external measurements.

The typical measurement time for a plain ring gauge is 40 s and 50 s for a threaded ring gauge, including automatic search of the reversal points.

C. Accurate and Reliable Results

The CNC controlled measuring carriage ensures a smooth measurement process with all accessories.

All functions, such as displacement speed, measuring force, probing movement and locking of the measuring carriage are controlled electronically. Therefore all kinds of user influence on measuring results will be entirely eliminated.

D. Ergonomic Workbench

The specially designed Workbench offers a compact and thoroughly thought out working place.

For difficult environmental conditions, it can be equipped with a vibration damping system.

2.

APPLICATION VERSATILITY

It is possible to check all kinds of gauges as plain ring gauges, plain plug gauges, pins, threaded ring and plug gauges, conical thread ring and plug gauges, gauge blocks, snap gauges, gauge bars etc.

A large range of accessories is available as standard. Accessories to suit special application can be supplied.



Checking of large plain ring gauges



Checking of small plain ring gauges from Ø 2 mm as standard



Checking of thread ring gauges from M3 as standard



Checking of plain plug gauges



Checking of thread plug gauges



Checking of master gauge blocks

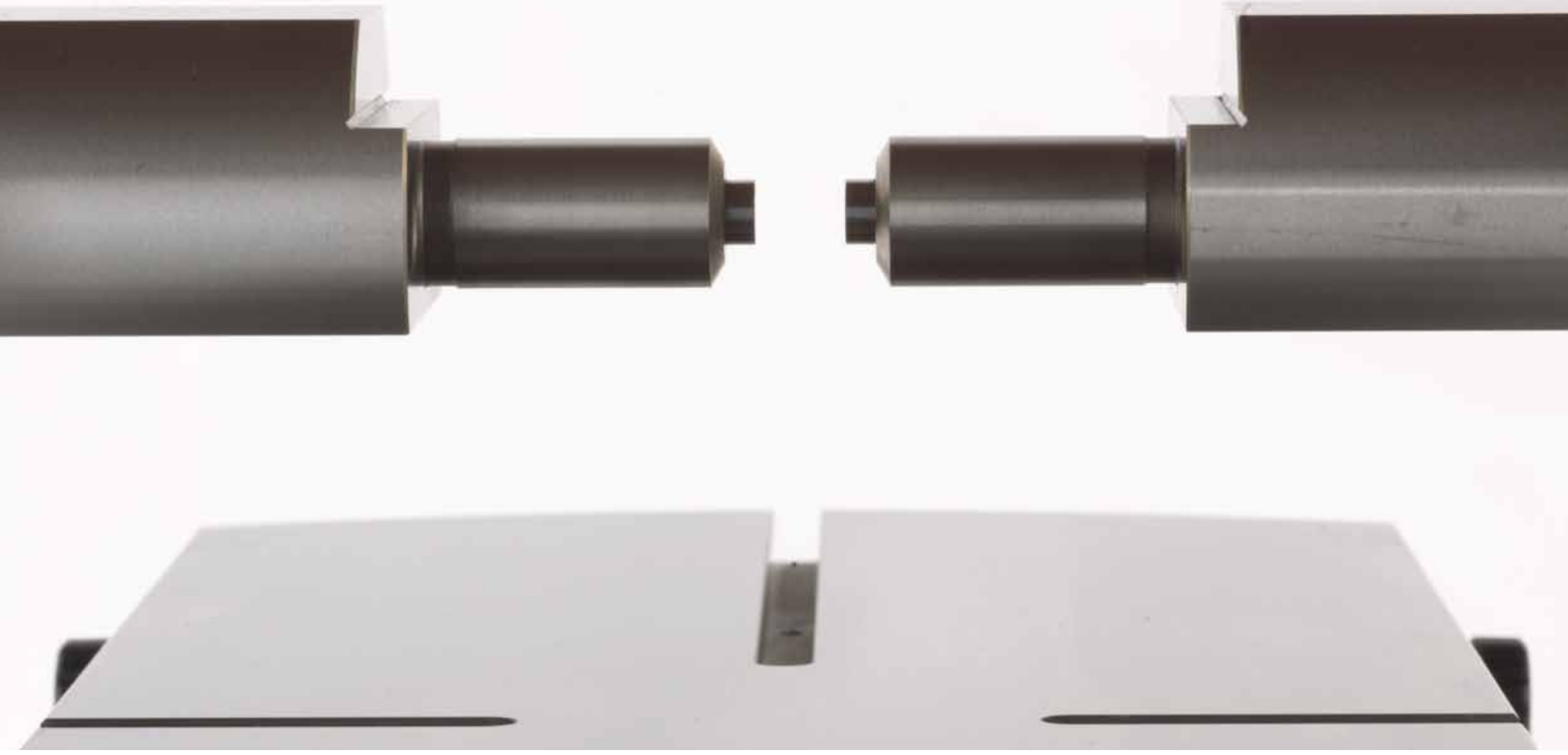

Checking of gauge bars

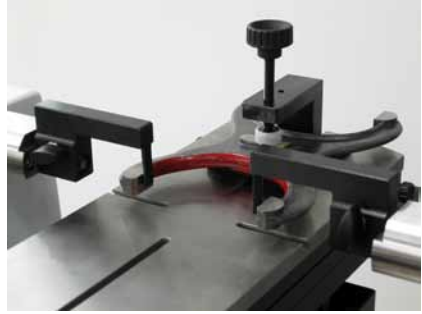

Checking of snap gauges



Checking of taper thread plug gauges

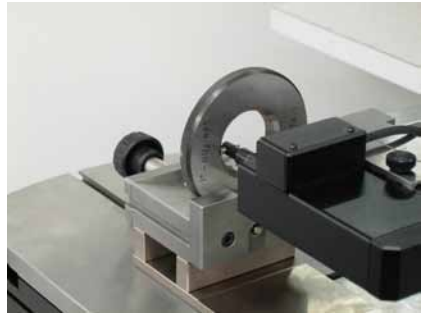

Checking of taper thread ring gauges

3.

QUICK AND EFFICIENT MEASUREMENTS



Temperature Compensation System Trimos® WinComp

The Labconcept Nano is equipped as standard with a temperature compensation system Trimos® WinComp allowing the acquisition and management of temperature data. It establishes a permanent connection with Win DHI,

guaranteeing real-time compensation of measurements according to the evolution of temperature. The user is constantly informed of the reliability level. The system can be switched on and off at any time.

Test Equipment Management System QMSOFT

Trimos recommends the QMSOFT (Quality Management Software) software package from L&W. This powerful system allows the inspection and management of gauge data of all measuring tools available according to national, international and user's defined standards. The calibration sequences for

standard measuring equipment with on-line data transfer from the instrument are realized by specially developed program modules for a perfect integration with WinDHI. Inspection certificates may be customized for individual presentation using a graphic editor.

Trimos® Win DHI Nano

Trimos® Win DHI Nano is the exclusive measurement software of Trimos. It is part of the basic equipment of the Labconcept Nano and allows the performance of all measuring functions. It helps the user to perform all measurement tasks through a user-friendly interface.

The motorization of the measuring carriage (X) and both, the vertical (Z) and horizontal (Y) axis of the universal measuring table allow an exceptional performance in terms of measuring speed, ease of use and accuracy.

Positioning can be done easily using the mouse and the keyboard or via the touch screen (optional) or a joystick (optional). Once positioned, measurements are entirely CNC controlled, searching the reversal point included. Plug and ring gauges, threaded ring and plug gauges etc. can be measured automatically in a few seconds. No risk of damage to the sensitive probes while moving or measuring, even with tiny parts and inserts.

4.

TECHNICAL SPECIFICATIONS

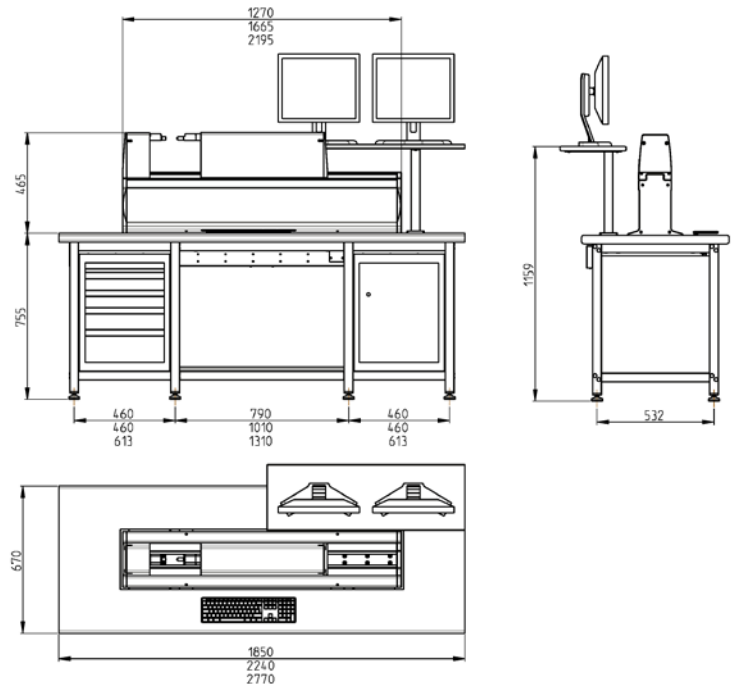

● LABCONCEPT NANO

		350	600	1100
Absolute measuring range ¹⁾	mm (in)	350 (13)	350 (13)	350 (13)
Application range	mm (in)	0 - 350 (13)	0 - 600 (23)	0 - 1100 (43)
Max. permissible errors ²⁾	µm	0.07+L(mm)/2000		
Max. resolution	mm (in)	0.000001 (0.0000001)		
Repeatability (2s) ²⁾	µm	0.03		
Measuring force (adjustable by software)	N	0 - 12		
Operational temperature	°C	+15° to 35° C		
Stocking temperature	°C	-10° to 50°C		
Relative humidity	%	20 .. 80		
Weight	kg	350	420	500

1) May vary according to accessory used.

2) Values valid at a temperature of 20 ± 0.2 °C and relative humidity of $50 \pm 5\%$.

● MEASURING TABLE WITH MOTORIZED Y AND Z AXIS

Z axis, displacement range ³⁾	mm	80
Y axis, displacement range ³⁾	mm	50
X axis, floating movement	mm	± 10
Angle of rotation φ Y	°	± 1.5
Angle of inclination φ Z	°	± 4
Max. weight of parts	kg	60

3) Both axes have an integrated measuring system.

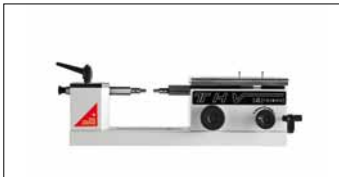

TRIMOS Calibration instruments

THV

Application Range : 100 mm
Absolute Measuring Range : 50 mm
Max. Permissible Errors : $0.2 + L$ (mm) / 250



LABCONCEPT

Absolute Measuring Range : 500 – 2000mm.
Max. Permissible Errors : $0.3 + L$ (mm) / 1500.



LABCONCEPT PREMIUM

Absolute Measuring Range : 300 – 1000 mm
Max. Permissible Errors : $0.15 + L$ (mm) / 2000



LABCONCEPT NANO

Application Range : 350 – 1100 mm
Absolute Measuring Range : 350 mm
Max. Permissible Errors : $0.07 + L$ (mm) / 2000

TRIMOS SA

Av. de Longemalle 5
CH - 1020 Renens
T. + 41 21 633 01 01
F. + 41 21 633 01 02
www.trimos.com